

REFLUX™ Flotation Cell

Enhanced flotation
hydrodynamics



Faster flotation. Better product quality.

The RFC™ repeatedly demonstrates a robustness to operate at extreme levels of gas flux, feed flux, and fluidisation wash water flux, an order of magnitude beyond existing flotation devices.

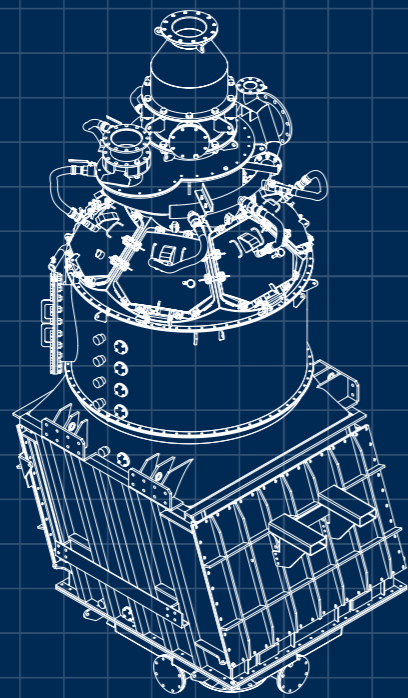

Key benefits

■ Up to 10 x higher throughput

■ Enhanced grade & recovery

■ Smaller footprint

■ Lower utility demands

Improved kinetics for fast, high-throughput flotation

A new flotation cell that radically alters the perception of productivity.

Confounding the conventional

The REFLUX™ Flotation Cell (RFC™) operates at a magnitude far beyond the capacity of existing flotation devices, reducing the required installation footprint. Its novel arrangement enhances the hydrodynamics of flotation, with the ability to recover a wide size distribution of minerals at a rate of up to 7-10 times faster than traditional methods.

This frothless system allows for stable flotation, enhanced gangue rejection, and quicker kinetics – pushing the boundaries on concentrate grade, recovery, and throughput well beyond the performance of conventional open tank systems.

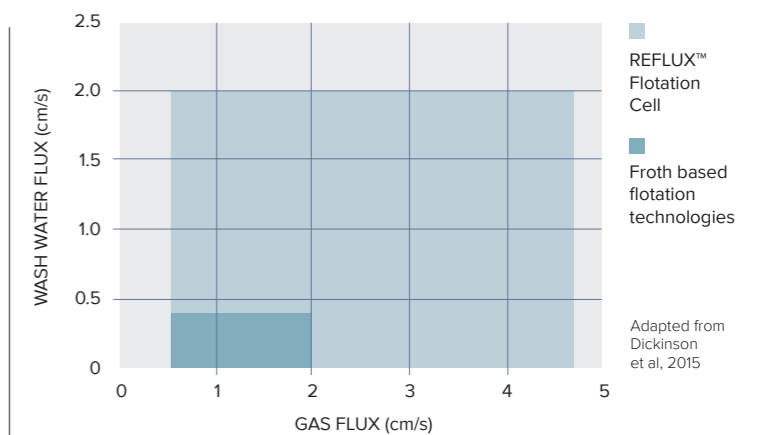

The ability to operate at gas and wash water fluxes above what is traditionally possible with any other existing flotation equipment sets this technology apart and allows for production of superior quality flotation product at elevated recovery.

The RFC is a very high capacity, efficient flotation technology capable of implementation in various applications.

- Rougher flotation
- Cleaning flotation
- Tailings re-treatment
- Offloading overloaded flotation circuits

“A single, full-scale REFLUX Flotation Cell is anticipated to provide an economical solution for industry to effectively replace ten flotation cells with a single unit, to rapidly recover valuable particles into a slurry concentrate. One additional unit should then be sufficient to fully clean the concentrate free of unwanted hydrophilic gangue particles.”

K. Jiang, J.E. Dickinson, K.P. Galvin,
University of Newcastle

Not only fast recovery of valuables, but at enhanced grades

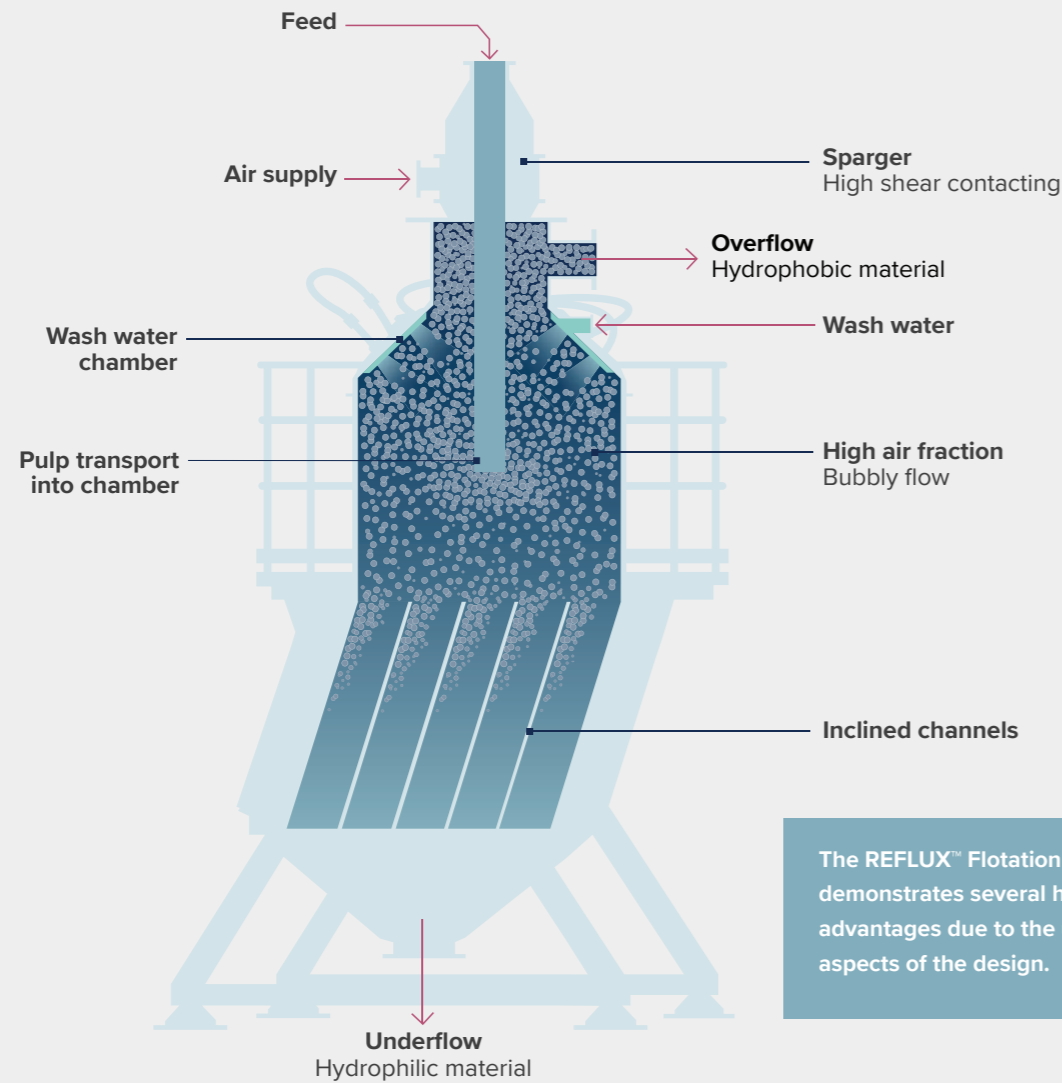

The REFLUX™ Flotation Cell (RFC™) demonstrates several hydrodynamic advantages due to the unique, novel aspects of the design.

The RFC consists of the main vertical vessel positioned above a system of inclined channels. The inclined channels enhance the segregation between bubbles and downward flowing liquid, allowing for operation at elevated internal gas fractions.

Feed and air are contacted in a high shear rate environment as it enters the cell via a central sparging system to expedite flotation kinetics.

The float product emerges through an annulus surrounding the sparger system, while the tailings discharge via the zone below the inclined channels.

A plenum chamber encloses the top of the cell, supplying clean fluidisation/wash water for counter-current washing of the rising bubbles with a positive bias flux to promote effective gangue rejection.

Focussed improvement of flotation fundamentals

The RFC combines several technologies to achieve superior flotation performance in maximising recovery, gas flux, bubble liquid segregation and product cleaning.

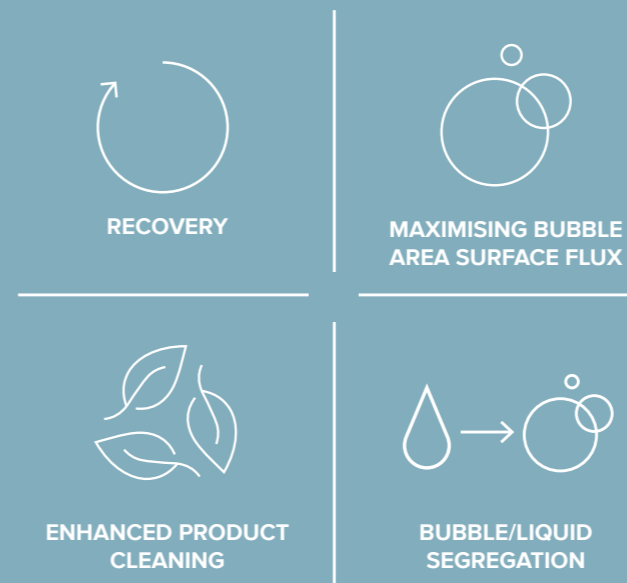

Recovery

Recovery rates are maximised by novel contacting of floatable material in a high shear rate environment promoting elevated collision and attachment rates. The unique plenum chamber further promotes recovery by eliminating operation with a defined froth-pulp interface.

Bubble Surface Area Flux

Operational gas rates exceed what is typically achievable, increasing available bubble surface area flux by a factor of four times. Overall circuit air requirements are consequently reduced to less than 50% of traditional system demands while offering:

- Improved attachment rates
- Improved collision rates
- Improved recovery

Enhanced Product Cleaning

Application of inverted fluidisation water for effective counter-current washing and gangue rejection producing high grade product at elevated recovery.

Bubble-Liquid Segregation

Prodigious separation of loaded bubbles from slurry containing non floatable material is achieved by implementation of inclined channels allowing operation under air flooded conditions resulting in operation at:

- Increased gas flux
- Reduced bubble size

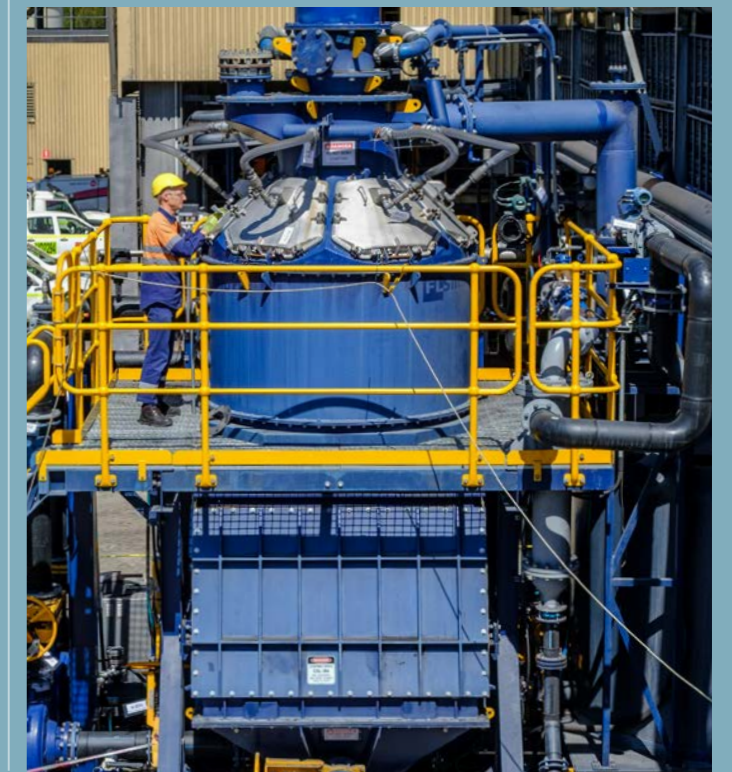

Versatility in implementation can expand your flotation capabilities

The RFC can be used in any flotation application ranging from rougher flotation to cleaning applications and across all mineral types. The high capacity nature of the technology allows for easy improvements.

Common applications

- Copper cleaning
- Copper scavenging
- Moly cleaning
- Gold tailings
- Iron ore
- Graphite
- Coal

The RFC utilises significantly less flotation volume than ordinarily required. These footprint saving not only translate into lower installation costs, but also offer savings in terms of air and wash water demands when considering overall flotation cross-sectional area. Footprint savings of up to 80% are possible.

Plug flow conditions within the cell reduce the number of flotation stages required to produce on-specification product grades at high recovery rates. Opportunities exist in applications such as graphite where multiple cleaning stages can be readily reduced while producing contract specification product.

Implementation in tailings retreatment applications offers additional revenue possibilities where marginal projects can become viable due to improved flotation efficiencies achieved by the RFC.

With no direct power input to the flotation machine, energy-constrained operations can benefit from the technology's lower energy demand. Up to 70% of flotation-related power savings can be realised.

- Superior metallurgical performance
- Smaller footprint in flotation circuit
- Fast kinetics - reduced operating volume required; robust processing capacity
- Improved metallurgical performance on slow floating and fine material
- Fewer flotation stages required
- Reduced power consumption per ton of ore treated



Frequently Asked Questions

Our experienced staff are ready and available to answer any questions you may have about this unique flotation technology. We are committed to finding the best solutions for your operation.

Is laboratory testing available?

FLSmith's Material Testing & Research Center is routinely used to perform scoping tests to establish baseline performance expectations for the RFC. Contact FLSmith for testing opportunities.

Is site pilot testing available?

Pilot site trials use a containerised test skid housed in a standard 20 ft shipping container. The test skid can be deployed quickly and can be commissioned in less than a week, with typical test programs wrapping up in 4 weeks or less. Utility and feed requirements are minimal with typical tests requiring less than 100 litres a minute of feed slurry.

What particle size range can this technology treat?

The RFC has been successful in treating feed materials ranging from ultra fine (<45micron) to coarser particle size distributions up to 2mm.



Can the RFC be retrofitted to my existing flotation cells?

The unique nature of the design and use of the lamella plates means this isn't something you can retrofit onto existing flotation cells. The technology by its nature does offer the ability to fit into space constrained areas and serve to off load overloaded flotation circuits or improve performance of existing circuits at a reduced cost.

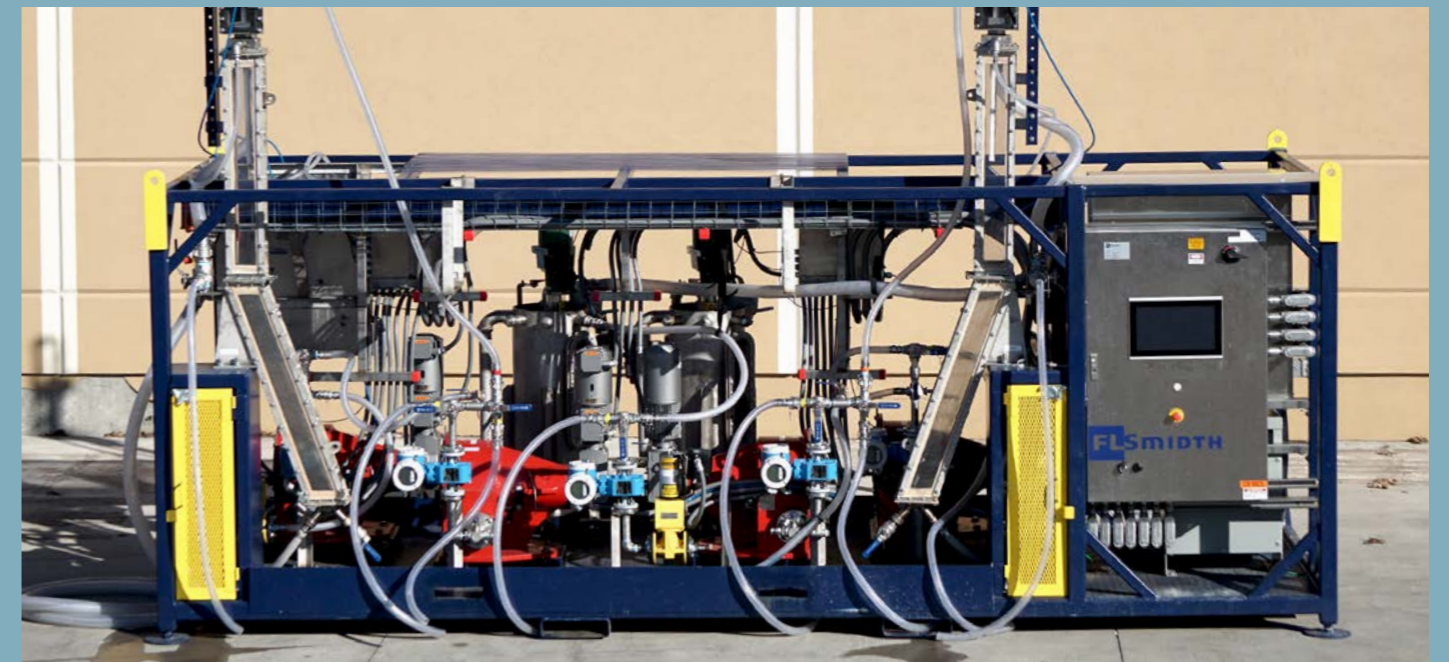

FLSMIDTH

Mission Zero

TOWARDS ZERO EMISSIONS IN MINING



Zero water
waste



Zero
emissions



Zero energy
waste

in

flsmidth.com/linkedin

t

flsmidth.com/twitter

f

flsmidth.com/facebook

@

flsmidth.com/instagram

▶

flsmidth.com/youtube

FLSmidth A/S
Vigerslev Allé 77
DK-2500 Valby
Copenhagen

Tel: +45 3618 1000
Fax: +45 3630 1820
E-mail: info@flsmidth.com

Copyright © 2021 FLSmidth. ALL RIGHTS RESERVED. FLSmidth is a (registered) trademark of FLSmidth. This brochure makes no offers, representations or warranties (express or implied), and information and data contained in this brochure are for general reference only and may change at any time.